

UNFINISHED SHAFT ENDS

Screw shaft diameter ϕ 15, Lead 5

(Unit : mm)

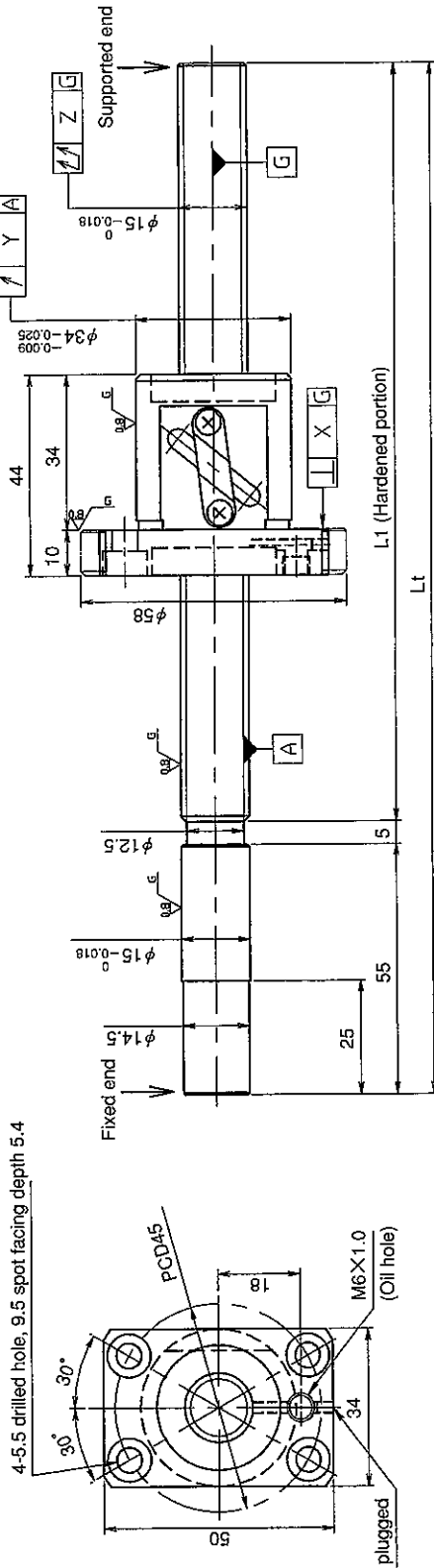

Model No.	Axial clearance	L ₁	L ₂	L ₃	L ₄	L ₅	L ₆	L ₇	L ₈	L ₉	L ₁₀	Preload torque (N·cm)		Lead accuracy		Wiper	Mass (kg)
												Z	Y	X	±Ec		
GE1505DS-BALR-0600A	~0.030 (M)	540	600	0.110	0.030	0.018	0.010	0.015	0.075	~2.0	0.030	0.023	0.046	0.030	0.018	Lip seal	1.19
GE1505DS-BALR-1100A	~0.005 (F)	1040	1100	0.210	0.030	0.018	0.010	0.015	0.150	~2.0	0.030	0.023	0.046	0.030	0.018	Lip seal	2.08
*GG1505DS-BALR-0600A	~0.005 (F)	540	600	0.110	0.030	0.018	0.010	0.015	0.075	~2.0	0.030	0.023	0.046	0.030	0.018	Lip seal	1.19
GG1505DS-BALR-1100A	~0.005 (F)	1040	1100	0.210	0.030	0.018	0.010	0.015	0.150	~2.0	0.030	0.023	0.046	0.030	0.018	Lip seal	2.08

• JIS B 1192-1987 (GG series) applies to accuracy standard values shown in the above-mentioned table.

• Support unit : BUK-12A (BUK-12F, BUK-10S) and BUM-12 is recommended. (Refer to P.398)

• Product with axial clearance ~0.005 (F) shown in the table may be partially preloaded.

• Preload torque shown in the table is a value before greasing.

• The grease is contained inside of the nut only at the time of delivery. When using it, apply lubricant.

• For asterisked * model with unworked shaft ends equivalent to lead accuracy grade C3, contact KURODA.

Ball screw specifications

Screw shaft dia.	15	Axial clearance	~0.030 (M)	~0.005 (F)
Lead	5	Basic dynamic load rating	6900N	
Thread direction	Right-hand	Basic static load rating	12500N	
Number of circuits	2.5turn 1circuit	Spacer ball	—	
Ball diameter	3.175	Lubricant	Alvania Grease No.2	

Table of optional specifications for each model

Series	Additional machining of shaft end	Axial clearance adjustment (Note 2)	Difference of grease	Direction of nut	Wiper removal
GE	○	○	○	○	○
GG	○	○	○	○	○

(Note 1) The above-mentioned surface treatment is LD treatment (coating thickness : 1 to 2 μm).

(Note 2) For axial clearance adjustment for GG series, contact KURODA.

Refer to page 24 for NOTATION OF MODEL NUMBER.

SHAFT END FINISH ORDERING SHEET

Screw shaft diameter ϕ 15, Lead 5

(Unit : mm)

GE1505DS-BALR- X -C7M
 GG1505DS-BALR- X -C5

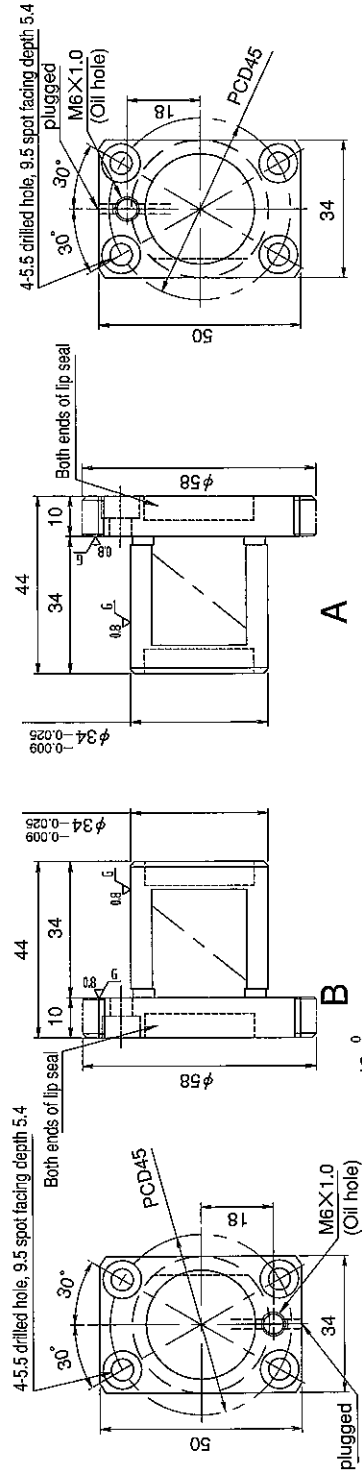

Select the orientation of nut flange by circling A or B.
 No marking means "B" orientation as default.

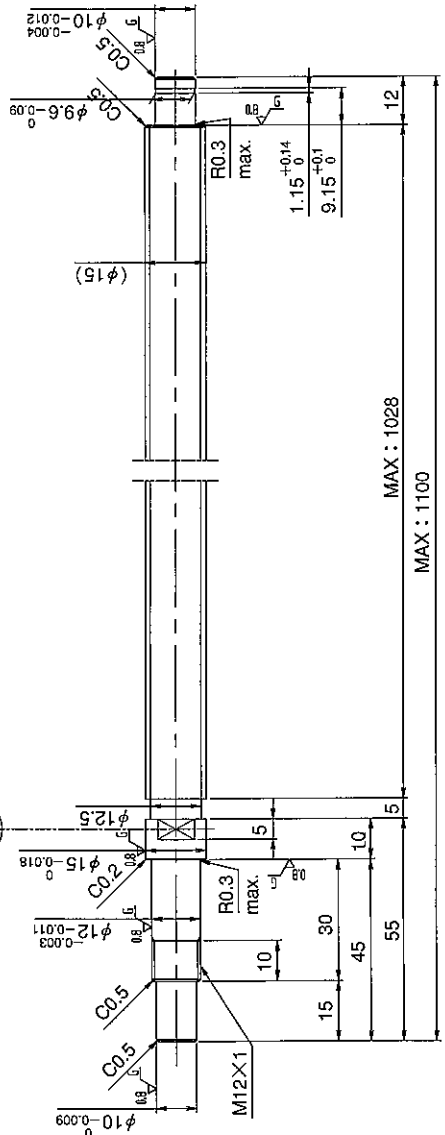

Applicable Support Unit
 Direct mount : BUK-12A (Fixed end unit+Supported end unit) Refer to Page.405
 Circle flange : BUM-12 (Fixed end unit+Supported end bearing) Refer to Page.412

Company Name	
Telephone	Name of Person in Charge
Company Address	