

Rexroth Ball Rail Systems

Standard Guide Rails, Hard Chromium-Plated

Guide rail
Chromium-plated 1645-
for mounting from above,
complete with plastic mounting
hole plugs

- The holes have a chrome coating.
- The end faces of composite rails are chromium-plated.

Versions:

- End faces not chromium-plated (except composite rails):
Part numbers, see table
- End faces chromium-plated:
Part numbers 1645-..3-41
- Guide rails with rail seal cover strip (new) available on request.

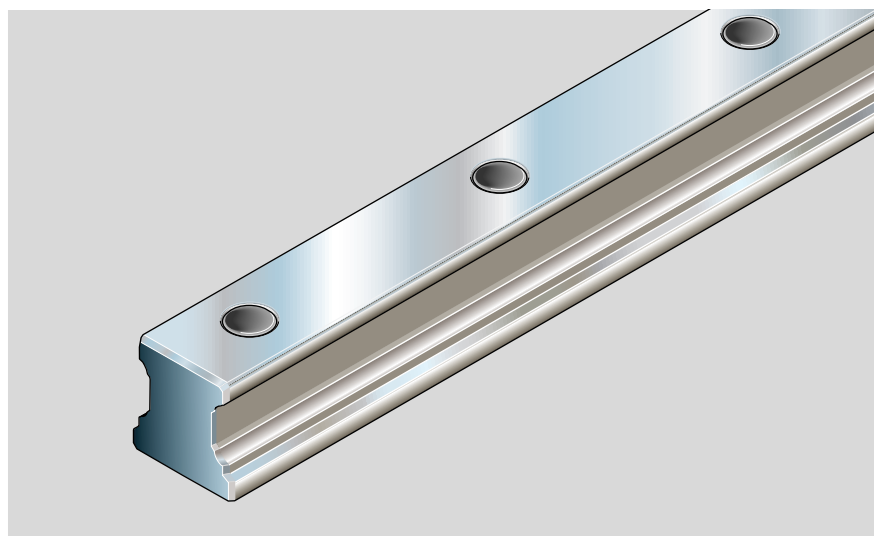

Part numbers and rail lengths

Size	Accuracy class	Guide rail		Spacing T (mm)	Recommended rail length				
		one-part Part number, Rail length L (mm)	composite Part number, Number of sections Rail length L (mm)		Number of holes n_B / Rail length L (mm)				
15	H	1645-103-31,....	1645-103-4,.....	60	2 / 116	7 / 416	12 / 716	20 / 1196	40 / 2396
					3 / 176	8 / 476	13 / 776	22 / 1316	50 / 2996
					4 / 236	9 / 536	14 / 836	25 / 1496	60 / 3596 ¹⁾
5 / 296	10 / 596	16 / 956	30 / 1796		66 / 3956 ¹⁾				
6 / 356	11 / 656	18 / 1076	35 / 2096						
25	H	1645-203-31,....	1645-203-4,.....		80	2 / 156	7 / 556	12 / 956	20 / 1596
30	H	1645-703-31,....	1645-703-4,.....	3 / 236		8 / 636	13 / 1036	22 / 1756	50 / 3996
				4 / 316		9 / 716	14 / 1116	25 / 1996	
				5 / 396		10 / 796	16 / 1276	30 / 2396	
6 / 476	11 / 876	18 / 1436	35 / 2796						
45	H	1645-403-31,....	1645-403-4,.....	105		2 / 204	7 / 729	12 / 1254	20 / 2094
					3 / 309	8 / 834	13 / 1359	22 / 2304	
					4 / 414	9 / 939	14 / 1464	25 / 2619	
					5 / 519	10 / 1044	16 / 1674	30 / 3144	
					6 / 624	11 / 1149	18 / 1884	35 / 3669	
55	H	1645-503-31,....	1645-503-4,.....	120	2 / 234	7 / 834	12 / 1434	20 / 2394	
					3 / 354	8 / 954	13 / 1554	22 / 2634	
					4 / 474	9 / 1074	14 / 1674	25 / 2994	
					5 / 594	10 / 1194	16 / 1914	30 / 3594	
					6 / 714	11 / 1314	18 / 2154	33 / 3954	
65	H	1645-603-31,....	1645-603-4,.....	150	2 / 294	7 / 1044	12 / 1794	20 / 2994	
					3 / 444	8 / 1194	13 / 1944	22 / 3294	
					4 / 594	9 / 1344	14 / 2094	25 / 3744	
					5 / 744	10 / 1494	16 / 2394	26 / 3894	
					6 / 894	11 / 1644	18 / 2694		

Dimensions and masses

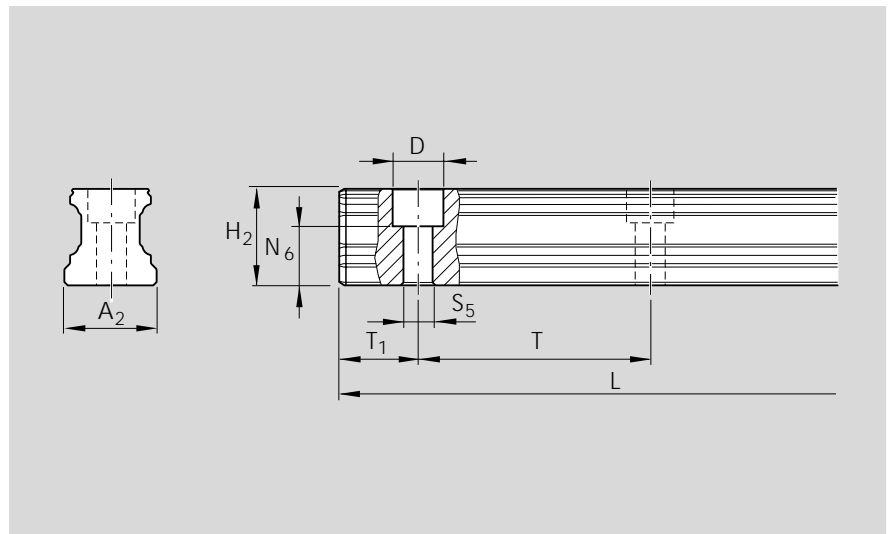

Size	Dimension (mm)									Mass (kg/m)
	A_2	H_2	$N_6^{\pm 0.5}$	D	S_5	$T_{1S-1}^{+0.5}$	$T_{1 \min}$	T	L_{\max}	
15	15	16.20	10.3	7.4	4.4	28.0	10	60	4000	1.4
20	20	20.55	13.2	9.4	6.0	28.0	10	60	4000	2.4
25	23	24.25	15.2	11.0	7.0	28.0	10	60	4000	3.2
30	28	28.35	17.0	15.0	9.0	38.0	12	80	4000	5.0
35	34	31.85	20.5	15.0	9.0	38.0	12	80	4000	6.8
45	45	39.85	23.5	20.0	14.0	50.5	16	105	4000	10.5
55	53	47.85	29.0	24.0	16.0	58.0	18	120	4000	16.2
65	63	59.85	38.5	26.0	18.0	73.0	20	150	4000	22.4

Recommended runner blocks

Recommended runner block:

Size 15 to 30:

- Runner blocks of accuracy class H to 10 μm clearance

Size 35 to 65:

- Runner blocks of accuracy class H to 0.02 C preload

Accuracy class H:

- Runner block optionally available as chromium-plated; part numbers available on request.

When using a combination of guide rails and runners block of different accuracy classes, the tolerances for dimensions H and A_3 change.

(Dimensions H and A_3 , see sections "Accuracy classes and their tolerances" at the technical data for runner blocks.) Exact values for the desired combinations are available on request.