

Rexroth Ball Rail Systems

Super Runner Blocks \mathcal{S} Steel Version

Super Runner Block \mathcal{S} with self-aligning feature 1662-

Slimline, short

Special versions:

Runner blocks in accuracy class N (clearance and preload 0.02 C) are also available:

- with low friction seals (part numbers 16...4-11).

Dynamic characteristics

Speed $v_{\max} = 3 \text{ m/s}$

Acceleration $a_{\max} = 250 \text{ m/s}^2$

Other technical data, see chapter "General Technical Data and Calculations".

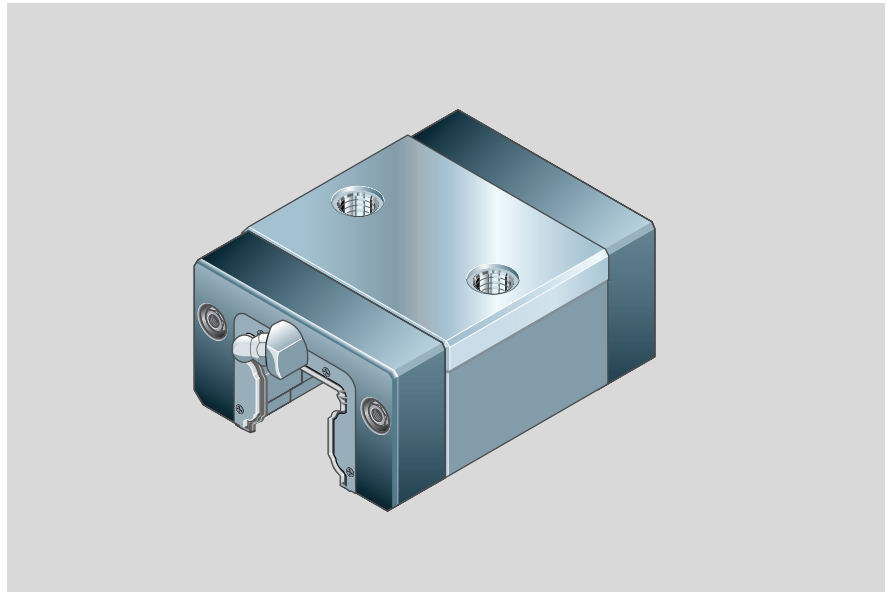

Part numbers

Size	Accuracy class	Part numbers for runner blocks for preload class	
		up to approx. 10 μm clearance	Preload 0.02 C
15	H	1662-193-10	1662-113-10
	N	1662-194-10	1662-114-10
20	H	1662-893-10	1662-813-10
	N	1662-894-10	1662-814-10
25	H	1662-293-10	1662-213-10
	N	1662-294-10	1662-214-10
30	H	1662-793-10	1662-713-10
	N	1662-794-10	1662-714-10
35	H	1662-393-10	1662-313-10
	N	1662-394-10	1662-314-10

Permissible load

When calculating the service life, use the maximum load capacity figure.

The permissible load is only limited for statistical purposes (see table).

Note on dynamic load capacities and moments (see table)

Determination of dynamic load capacities and moments is based on a travel life of 100 000 m.

However, frequently this is determined on the basis of only 50,000 m.

In this case for comparison: multiply values **C** and **M_t** by 1.26 in accordance with Rexroth table.

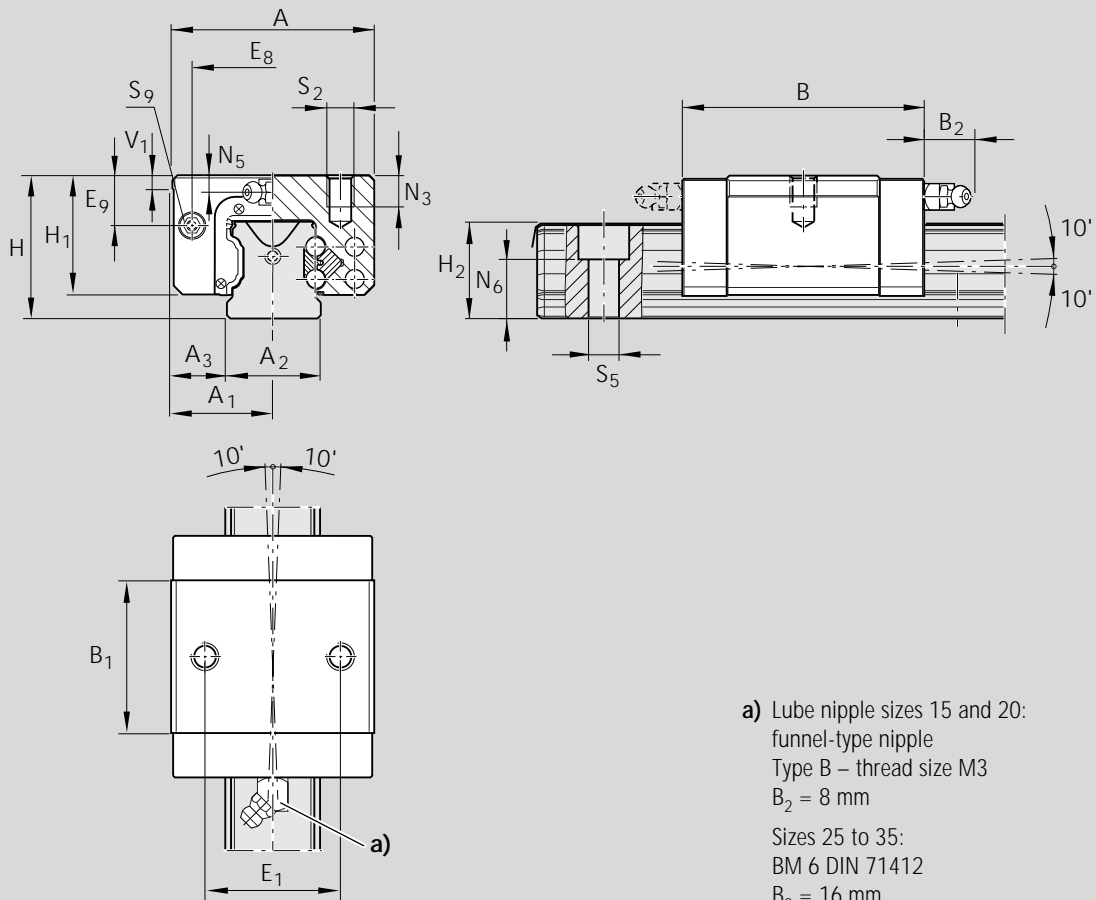

- a) Lube nipple sizes 15 and 20:
 funnel-type nipple
 Type B – thread size M3
 $B_2 = 8 \text{ mm}$
 Sizes 25 to 35:
 BM 6 DIN 71412
 $B_2 = 16 \text{ mm}$
 Connection possible at either end.

Size	Dimensions (mm)														
	A	A ₁	A ₂	A ₃	B	B ₁	H	H ₁	H ₂ ¹⁾	H ₂ ²⁾	V ₁	E ₁	E ₈	E ₉	N ₃
15	34	17	15	9.5	40.5	25.7	24	19.8	16.3	16.20	5.0	26	24.55	6.7	6.0
20	44	22	20	12.0	52.5	31.9	30	25.4	20.7	20.55	6.0	32	32.4	7.3	7.5
25	48	24	23	12.5	61.5	38.6	36	29.5	24.4	24.25	7.5	35	38.3	11.5	9.0
30	60	30	28	16.0	71.5	45.0	42	35.0	28.5	28.35	7.0	40	48.4	14.6	12.0
35	70	35	34	18.0	79.0	51.4	48	40.0	32.15	31.85	8.0	50	58.0	17.5	

¹⁾ Dimension H₂ with rail seal cover strip

²⁾ Dimension H₂ without rail seal cover strip

Size	Dimensions (mm)					Weight (kg)	Load capacities (N) C dyn.	Permissible load (N) F _{max}	Moments (Nm)	
	N ₅	N ₆ ^{±0.5}	S ₂	S ₅	S ₉				M _t dyn.	M _t max.
15	4.0	10.3	M4	4.4	M2.5-3.5 deep	0.12	3 900	1 500	39	15
20	4.7	13.2	M5	6.0	M3-5 deep	0.25	10 100	3 900	130	50
25	5.5	15.2	M6	7.0	M3-5 deep	0.40	11 400	4 400	170	65
30	6.0	17.0	M8	9.0	M3-5 deep	0.65	15 800	6 100	270	105
35	7.0	20.5	M8	9.0	M3-5 deep	0.95	21 100	8 100	450	175